

# TCME32 Series

32.768kHz TCXO, 3.2 x 2.5mm, HCMOS



µA current consumption



Parameters		Specification	Remarks
Frequency range		F_nom 32.768kHz	
Supply voltage		Vcc 1.8V, 2.5V, 3.0V, 3.3V, 5.0V	±5% voltage change, ±10% for 5V
Supply voltage variation		0.25V max.	ΔV/ΔT = 1V/us
Initial frequency tolerance		F_tol ±1.5ppm max.	At +25°C±3°C
Frequency stability	vs Temperature	F_stb ±5.0ppm	
	vs Load change	F_load ±0.2ppm max.	±10% load condition change
	vs Voltage change	F_Vcc ±0.2ppm max.	±5% input voltage change
	vs Aging	F_age ±3.0ppm/year max.	At +25°C
	vs Reflow	±1.0ppm/year max.	1 reflow and measured after 24hrs
	vs all range Vcc	±1.0ppm/volt max.	Vcc = 1.7V to 5.5V
Operating temperature range (°C)		Topr -40°C ~ +85°C	Table 1
Storage temperature (°C)		Tstg -55°C ~ +85°C	
Output wave form		HCMOS	
Output load		15pF	
Output voltage high		Voh Vcc - 0.4V min. loh = -0.1mA	For all Vcc range
Output voltage low		Vol 0.4V max. lol = 0.1mA	For all Vcc range
Current consumption		Icc 0.79µA ~ 2.05µA	Table 2
Rise and fall time		Tr, Tf 100ns max.	20% to 80% of waveform
Duty cycle		SYM 40%/60% typ.	Measured at 50% Vcc
Start-up time		T_str 1.0 sec max at 25°C	3.0 sec max at -40°C~+85°C
Pad 1 OE thresholds		Vih = 0.8Vcc, Vil = 0.2Vcc	
Timing error over time		±0.432sec/day	For ±5ppm over -40°C ~ +85°C

Note: The device is ESD sensitive and moisture sensitive level (MSL) - 1

Table 2 Supply voltage vs current consumption

Supply voltage (V)	Current consumption Icc (µA)
1.8V ± 5%	0.79µA
2.5V ± 5%	1.05µA
3.0V ± 5%	1.25µA
3.3V ± 5%	1.37µA
5.0V ± 5%	2.05µA

Dimensions(Unit:mm)

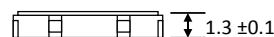
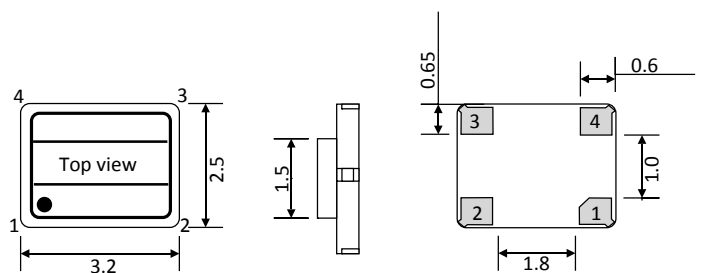

- Pad 1 : Output enable
- Pad 2 : Ground
- Pad 3 : Output
- Pad 4 : Supply voltage

Pad 1	Pad 3 (Output)
Enable (>Vcc*0.8)	Active
Disable (<Vcc*0.2)	High impedance

TCXO part number generation											
TC32M	00003	F	B	B	N	B	X	X	S	L	-PF
ACT series Code	Frequency (MHz) Ex. 32.768kHz	Temp. stability (±ppm)	Supply voltage (V)	Operating temp. range (°C)	Frequency tuning (±ppm)	Output wave	Mechanical tuning (±ppm)	Polarity	Duty Cycle	Tape & Reel	RoHS Code
TC32M	5 digit require to specify kHz frequency.  ≤ 99.99kHz 10=00001 32.768=00003  ≥ 100kHz 100=00010 250=00025	5.0 = F	1.8V = D 2.5V = C 3.0V = E 3.3V = B 5.0V = A	-40 ~ +85 = I	None = N	HCMOS = E	None = X	None = X	40%/60% = S	Loose = L 1000 = C 3000 = D	-PF

Note: It is important to suffix the above part number with full frequency required to give a completed part number as illustrated below.  
Full Example part number : **TC32M00003FBBNEXSL-PF [32.768kHz]**

### Test circuit

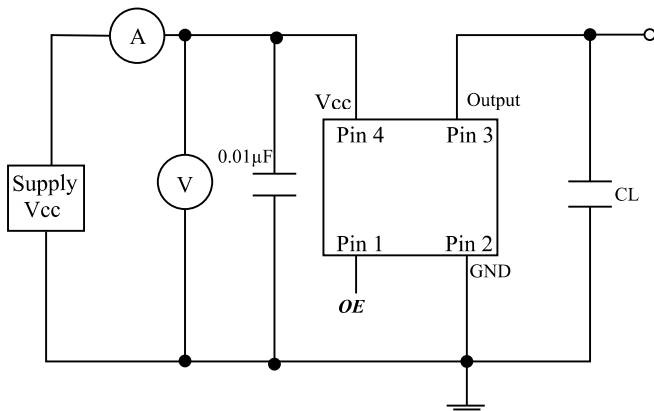

### Test waveform

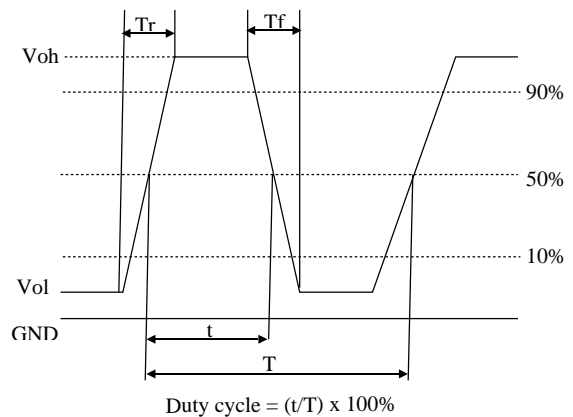

### Solder reflow profile

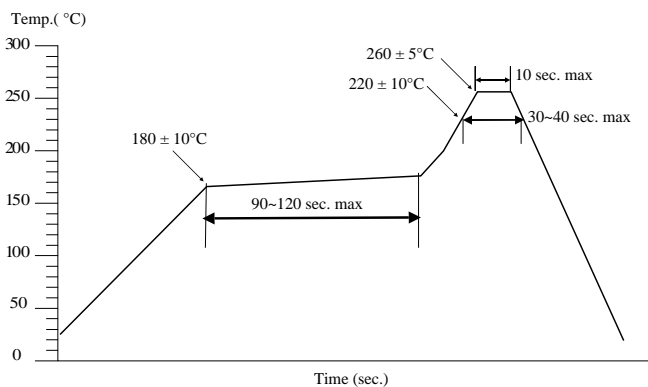

Drawing control: (Internal use only)  
Commodity code: 854370 90 99  
Issue number : 2  
Date : 17062016  
Internal reference : M6